

JYFLHJYA-2024

2024 4

2024

2024

	1
1	1
1.1	1
1.2	1
1.3	5
1.4	6
1.5	6
1.6	8
2	10
2.1	10
2.2	11
2.3	19
2.4	37
3	41
3.1	41
3.2	41
3.3	42
4	44
4.1	44
4.2	45
4.3	49
4.4	49
4.5	51
5	53
5.1	53
5.2	54
5.3	59
5.4	62

5.5 63

5.6 63

5.7 63

5.8 64

10.3	99
10.4	100
11	102
11.1	102
11.2	103
11.3	103
	104
	104
1	104
2	106
3	106
4	108
5	109
6	116
7	117
	118
1	118
2	119.....	119
3	

..... 133

..... 134

..... 134

..... 136

..... 138

..... 140

..... 142

..... 144

..... 146

1

1.1

1.2

1.2.1

1	2007	11	1
2	2015	1	1
3	2017	6	27
4			
	2018	10	26
5	2019	1	1
6	(
	2020	9	1)
7	2021		
8	2021		
9	2018.12.29		

1.2.2

1	2005	1	26	79
---	------	---	----	----

2006 1 8

2 2014 119

3 2022

4 2021 15 2020 11 5

2021 1 1

5 2013 12 4 32

2013 12 7

6 2002 4 30

57 2002 5 12

7 2024 5

8 2009 130

9 2011 17

10

2015 4

11

2016 74

12 2021

16 2020 11 5 2021 1 1

13 HJ 941-2018

14

15 HJ 589-2021

16 DB 37/T 3599-2019

17

18 (2014 15)

19 2021 14

20

21

2016 141

22		2020	37
23		2023	42
24			
		2020	1 1
25		(2016
37)		
26		2024	5
27			<
	>	2017	21
28			
		2018	8
29		2022	6
1.2.3			
1		GB18218-2018	
2			GBZ 2.1-2007
3			GBZ 2.2-2007
4		GB12268-2012	
5			GB/T29639-2013
6			GB30077-2013
7		GB18597-2023	
8			GB18599-2020
9	Seveso III Directive		III
10			GB30077-2013
11			GB50974-2014
12		GB50140-2005	
13			HJ169-2018
14			HJ2025-2012
15		GB6222-2005	
16			

2011	142		
17		HJ/T166-2004	2004 12 9
2004	12 9		
18		HJ164-2020	
19	<		>
2021	1	2021.01.05	
20			2020.05.21
21		GB 6222-2005	
22		GB50406-2017	
23		DB37/ 990-2019	
24		DB 37/990-2013	
25		DB 37/2376-2019	
26			2019 35
27		GB 13456-2012	
28			(
2022	231)		
29		GB50406-2017	
30		2	HG/T4335.2-2012
1.2.4			
1			
		2016	12
2			
		2019	9
3			
		2020	12
4			2021
		371212-2021-078-M	
5			

1.3

1

2

3

1.4

1

2

3

4

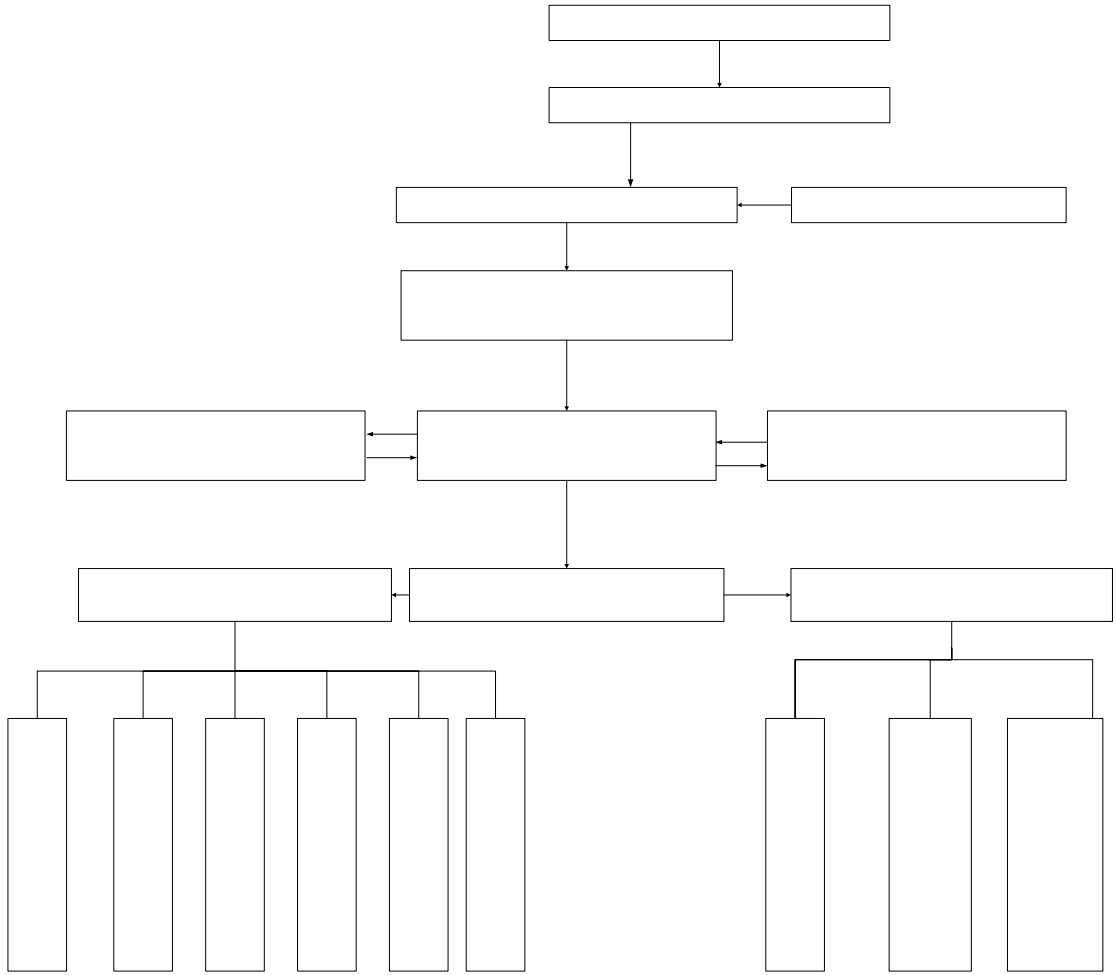

1-2

1

2

3

1.6

1

2

3

4

2

2.2

1

36 40 117 00

117 19 04 117 58 05 36 01 54

36 33 10

1739.61

205

2

7 3000 900

600

59.89% 20.34% 19.77%

7 14 148.13

994

3
1

Q

2.4m

1m

46m

K2-Eg

10°

P1-

-

C2P1t

C2b

150m

50m

O2-3M

25°

4O1s

3-4g

3z

4O1s

3z

5~15m

1000~3000m³/d

500m³/d

1000m³/d

1~5m

1~3m

0.11 0.73g/l

HCO₃-Ca

100m³/d

500m³/d 500~1000m³/d

1000~5000m³/d

HCO₃-Ca Mg

0.5~0.8g/l

20~30m

100m³/d

4~6m

2

1

6~9

2

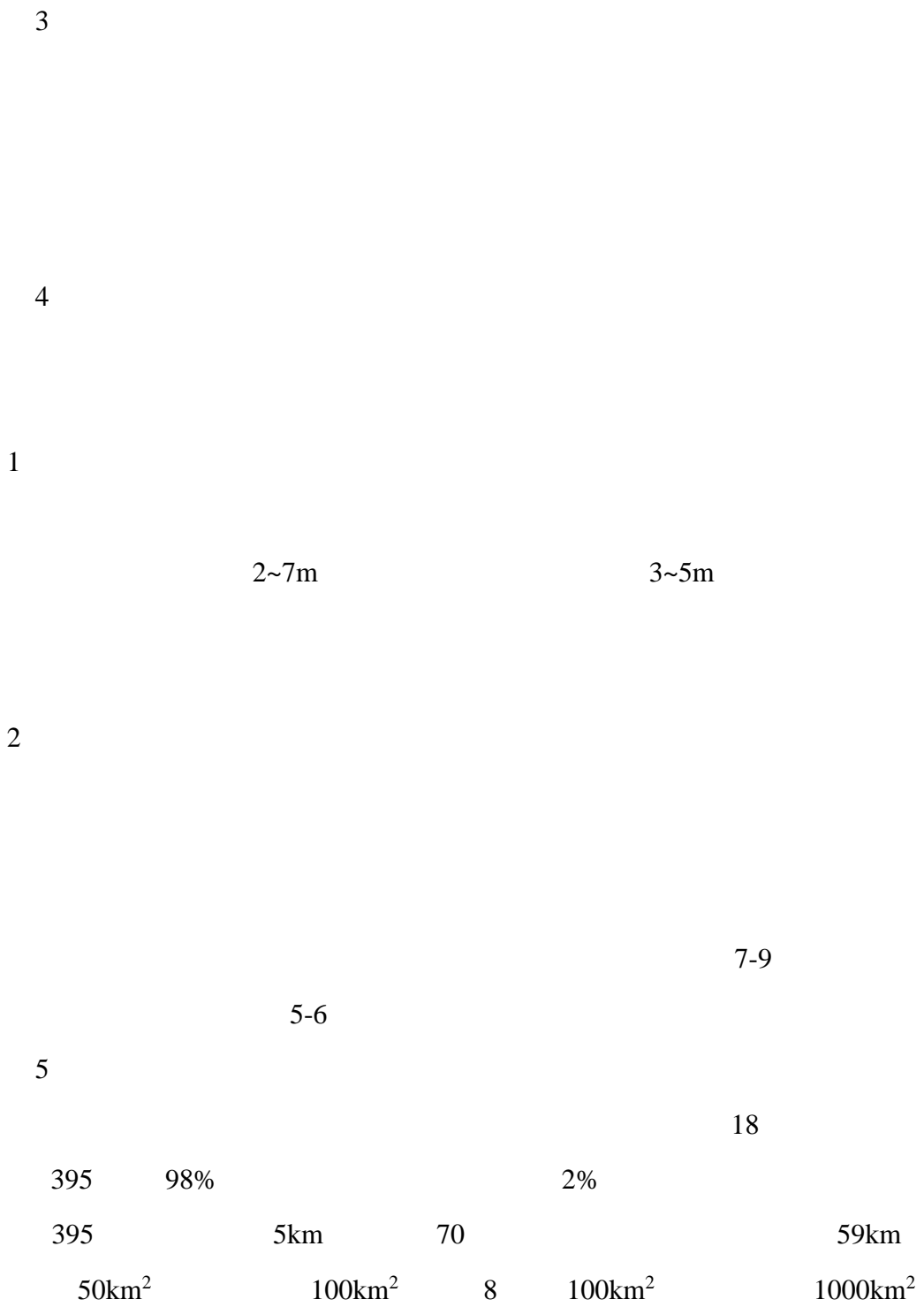

4 1000km² 1
5 20 80
613 2.08 m³

65.5km 1214km² 100 500m

22.5km 82.2km² 3 40 150m

6

2016 25

3

7

2019 238

3

6

7

39.9
26
62%
178mm

60%
752.1mm

13.5
-15.6
258mm

-5.3
72%
936.2mm

	1#-3#	1 1000m ³ 4# 5#
	4# 5#	1 1000m ³

2.3-1 2

	2×420m ³	1280m ³ 2×1650m ³
	TRT	4
	4×75m	4×50m
	1#	2#3# 4# 5# 4

2.3.2

2.3-2

2.3-2

			t/a
1		PB	5010916

		FB P +	
2			627166.5
3		3~0mm	615576
4		25~0mm	313058
5		40mm	33013.6
6		/	818251.6
7		/	236099.5
8		20%	1155
1		10 ⁴ kWh/a	30208
2		10 ⁴ m ³ /t	111.6
3		10 ⁴ m ³ /a	3948
4		10 ⁴ GJ/a	26.28
5		10 ⁴ Nm ³ /a	1216.8
			t/a
1		5~150mm	6441373
			t/a
1			5786326
2		6~18mm	424876
3		5~30mm	1050221
4		/	1773042
5		/	516525
1		10 ⁴ kWh/a	10160.92
2		10 ⁴ m ³ /t	224.63
3		10 ⁴ m ³ /a	273876.48
4		10 ⁴ m ³ /a	1172
5		10 ⁴ t/a	259.56
6		10 ⁴ Nm ³ /a	9142
7	2%	10 ⁴ Nm ³ /a	22177
8		10 ⁴ Nm ³ /a	14094
1	+	t/a	4258890
2		m ³	763016
3		10 ⁴ kWh/a	1917

2.3-3

2.3-3

		1m×2.5m×0.72m	2
		140m ²	2
		G4-73.NO18D	4
		LK-22.5m	2
		LDA-10	1
		TDSS2690	2
			1
		315×4157×3147mm	2
		130m ²	2
		113m ²	2
		75m ²	1
		320m ³	2
		320m ²	2
		Y3790/48K	14
		LK-22.5m	4
16T		GD16/32-13.5A5	2
		LHBJ-V150×600	4
			2
			2
		130m ³	2
		113m ³	2
		75m ³	1
		220m ³	2
		1200x1000	4
		B650	8
		B800	24
		B1200	34
		PDx 32SDF1	32
		1000x7180x10	32
		400x2000mm	4
		400	4
		3800x14000mm	2
		4400x18000mm	2
		1282x4046mm	2
		3100x7800mm	2
		XB1640x2460	2
		XB1640x3100	2
		XB1640x2200	2
		900x700	2
		B650	15
		B1000	12
		B1200	2
		1000x5000x10	15

	J360	2
	3000x12000mm	1
	3000x12000mm	1
	1500x2740mm	2
	XBSFJ-1 185x500	1
	XBSFJ-1 185x520	1
	HYC-5500	1
	420m ³ ×2	2
	1250m ³	1
	1650m ³	2
	KJ-IA(DLYA)	2
	YYG250C2-13	2
	KJ4000F	4
	KD300	2
	KD100	2
	YP3080	4
	Y4-2×73-23F	1
	Y4-73-24.5D	1
	Y4-2×73-1NO23F	1
	Y5-2×51-11NO23.5F	2
	Y4-2×73-21F	1
	Y4-73-11NO-25D	1
	Y4-73-23D	1
	Y4-2×73-1NO23F	2
	9-38-140GB/T13275-9	2
	9-26-12-50	2
	9-19-11-160	2
	1750SIBB50	2
	1850SIBB50D	2
	130×8000	3
	130×6000	2
	176×6000	9
	176×6000	5
	60m	2
	75m	2
		1280 1 3
		1650 1 3
		1650 1 3
		350 1 3
		420 1 3
	4800x3540x6972	3
	2420x1340	3
	800x600	3
	TZ3B-01-02	6
	6000x2400	3
	6mx8mx6m	3
	12mx8.5mx1.2m	2

		14mx8mx4m	1
		9mx16mx6m	3
		1m ³	3
		11m ³	2
		100m ³	1
		2.87m ³	1
		20m ³	2
		1.38m ³	13
		3m ³	4
		13m ³	1
		1.5m ³	2
		0.5m ³	1
		10m ³	3
		5.09m ³	2
		6m ³	1
		3.4m ³	2
		50m ³	1
		18m ³	1
		KQSN600-M9/751	8
		XBC5.9/410-400N9/486	4
		KQSN350-M6/654	8
		XBC6.0/210-300M9/445	4
		KQSN150/460-75/4	12
		XBC8.0/55-W150*25*4	4
		KQSN300 N9/445	8
		KQSN150-M9/206 T	12
		KQSN300-M9/387 T	12
		KQSN250-M9/327	8
		KQSN300-M13/313	12
		LF-47(B) :7.35 ×104m ³ /h	8
		DN300	5# 2
		DN450	5# 2
		JHGXY-3600	5# 2
		ZP9x3	5# 12
		LF50S	5# 2
		3600	4# 2
		STDN450	4# 2
		STDN300	4# 1
		GSL-3.0	1# 1
		ZTGL-3000	1# 1
		ZZL-300-1	2#3# 1
		ZZL600-1-6/200	2#3# 1
		JLD-BZ600-L6/0.2	2#3# 2
		ZJVI600	2#3# 1
		YLF2001-4-V ₁	2#3# 1

		LF-47	2#3#	1
		ZP9x3	1#	27
		ZP9x3	4#	12
		Q=750m ³ /h	4#	2

2.3.3

A.

2.3-1

2.3-2~2.3-3

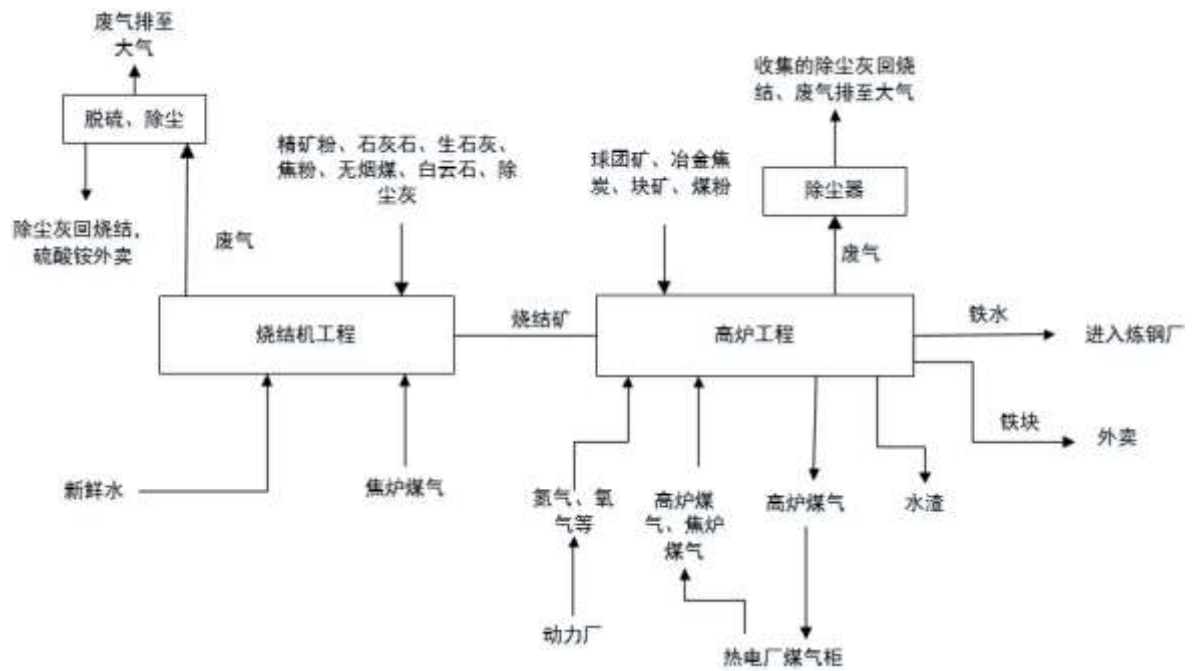

2.3-1

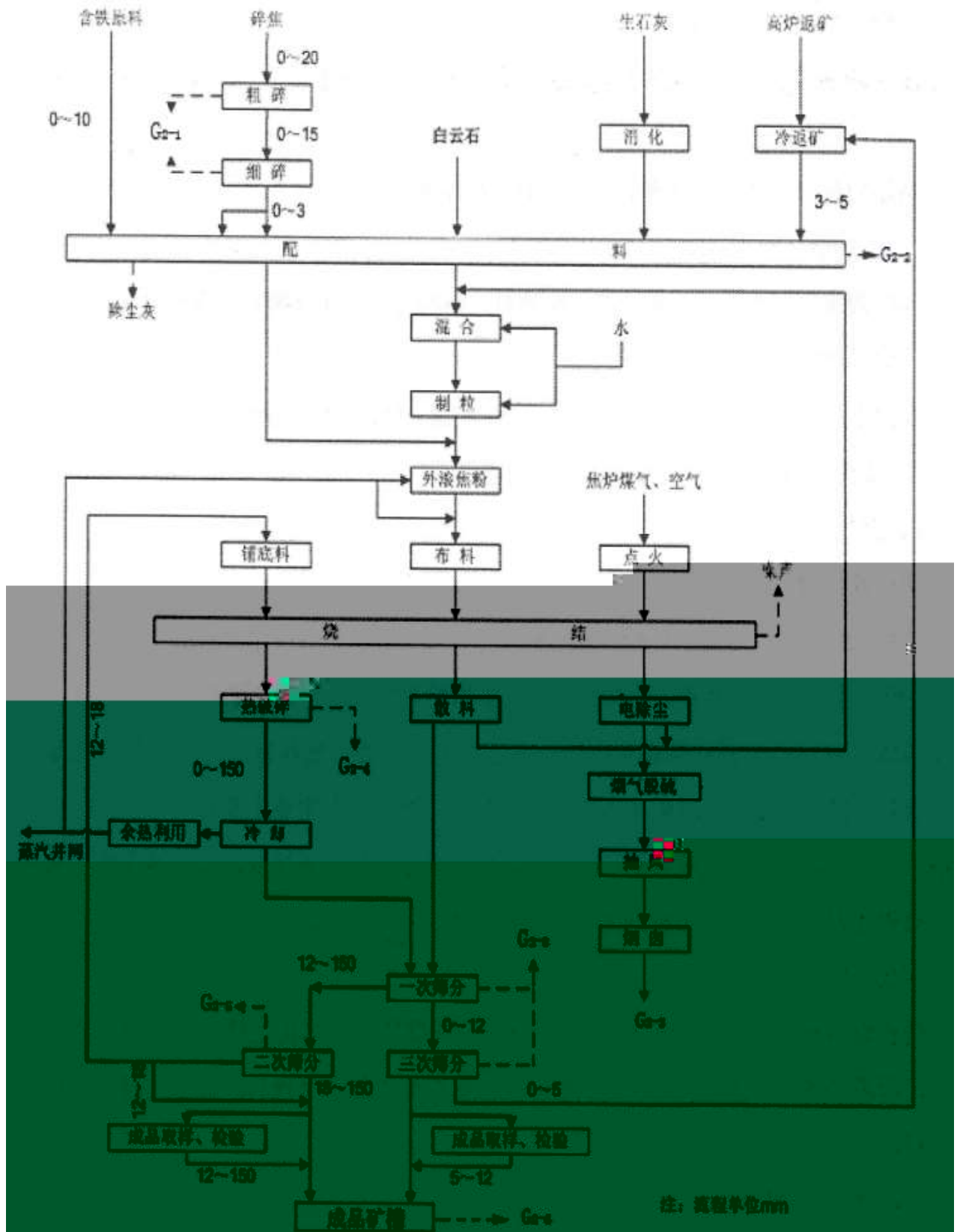

2.3-2

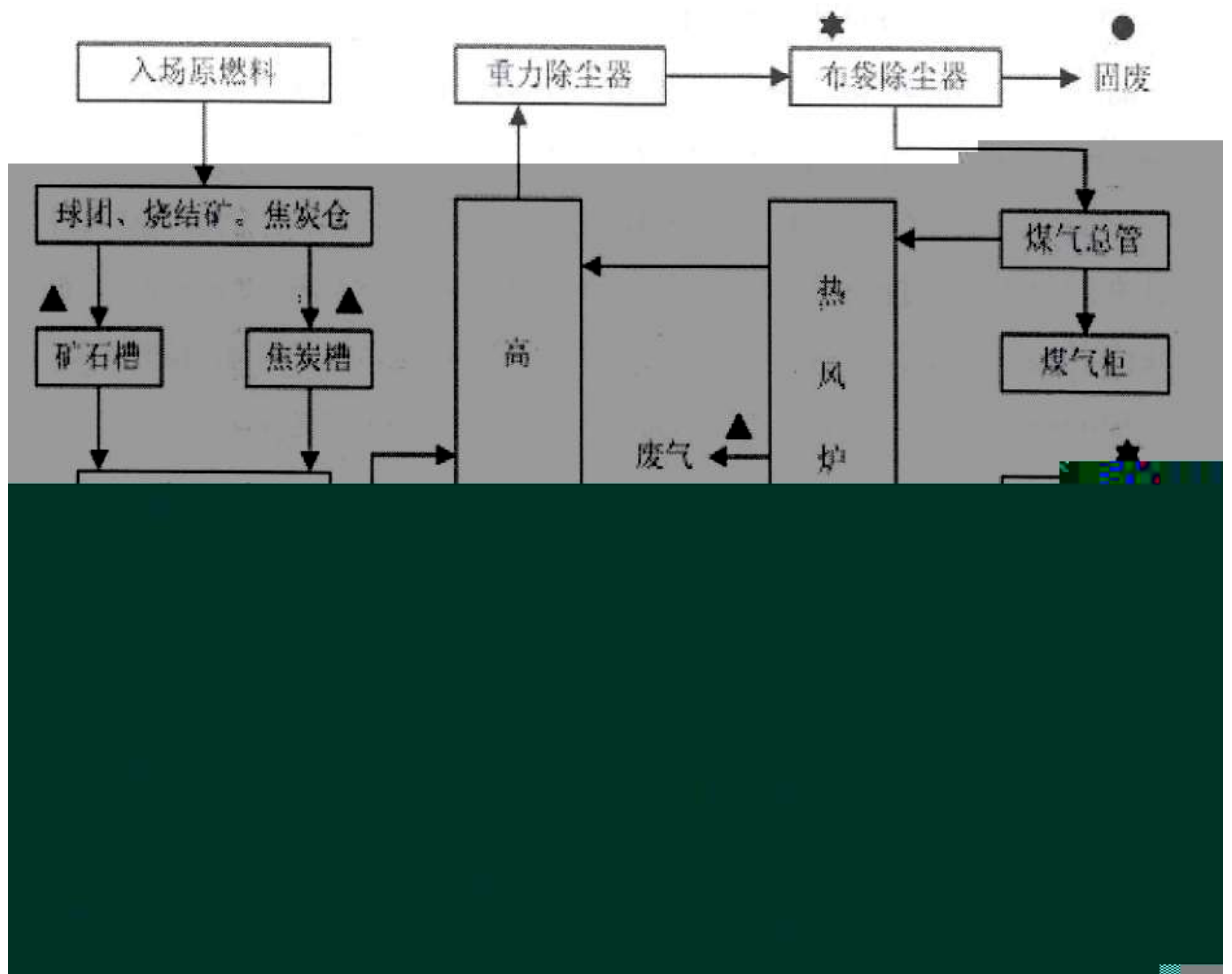

2.3-3

1

1

(<3mm)

2

2

16

3

1

4

1 00×18000mm

5

10 20mm

30 50mm

150mm

150

6

3

2

>5mm

2

1

2

/

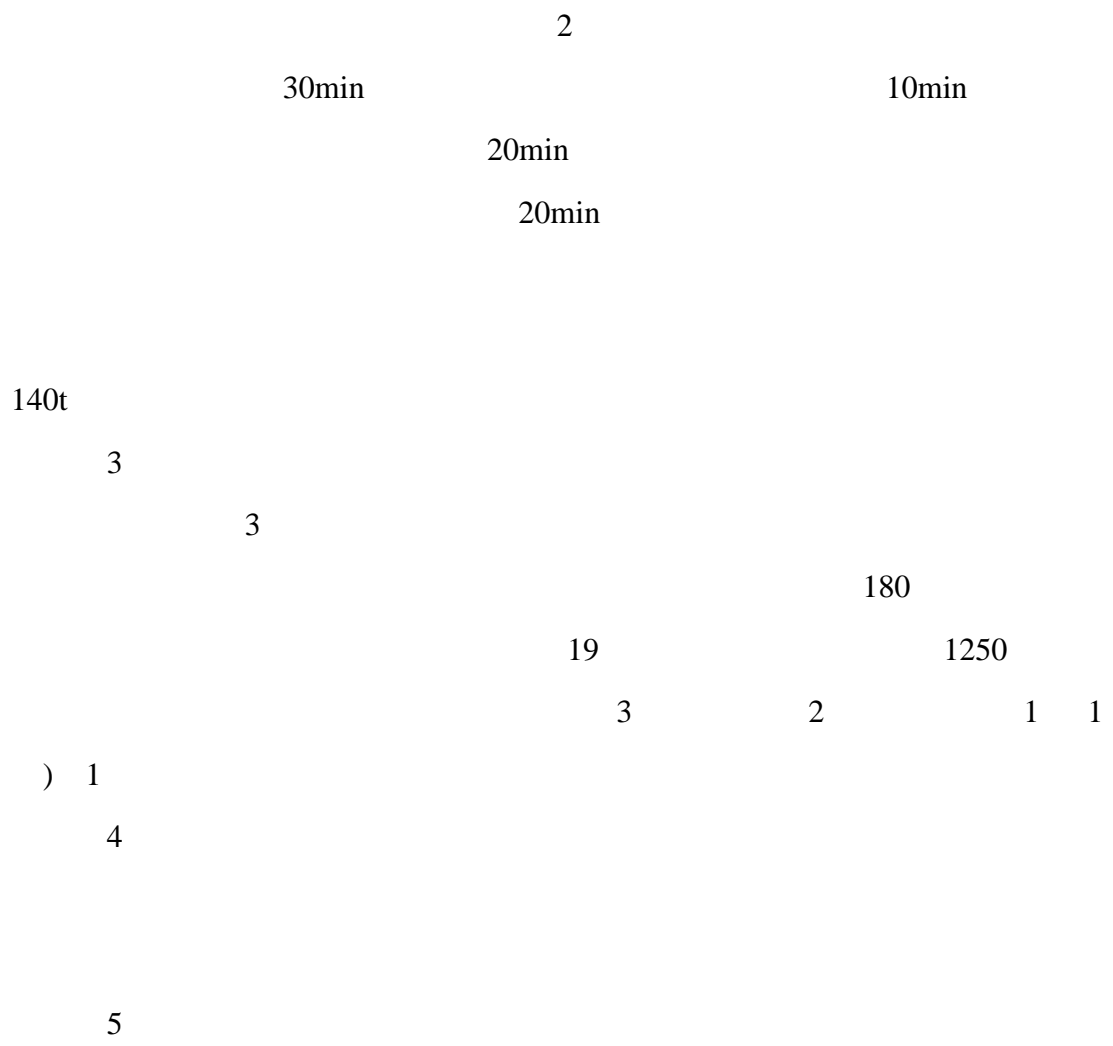

1.2-4.0mm

1

7m

6

4

1

1

6~10g/m³

7

2.3-8

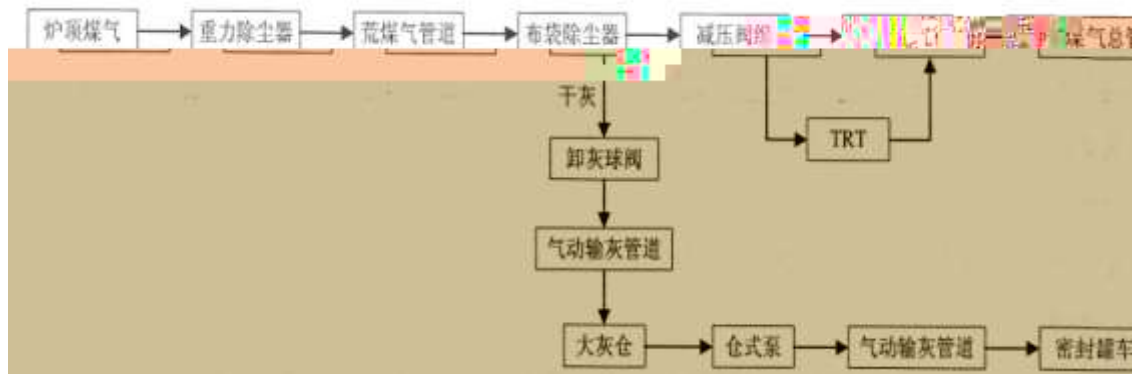

2.3-4

90~260 °C

260 °C

90 °C

TRT

TRT)

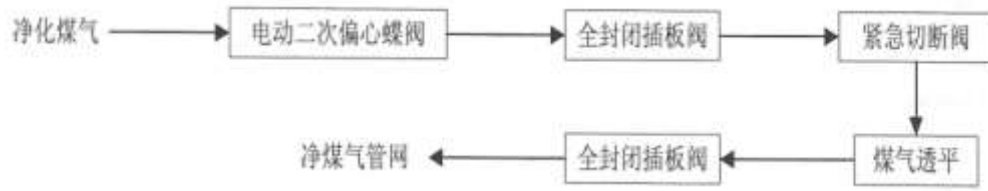

2.3-5 TRT

8

TRT

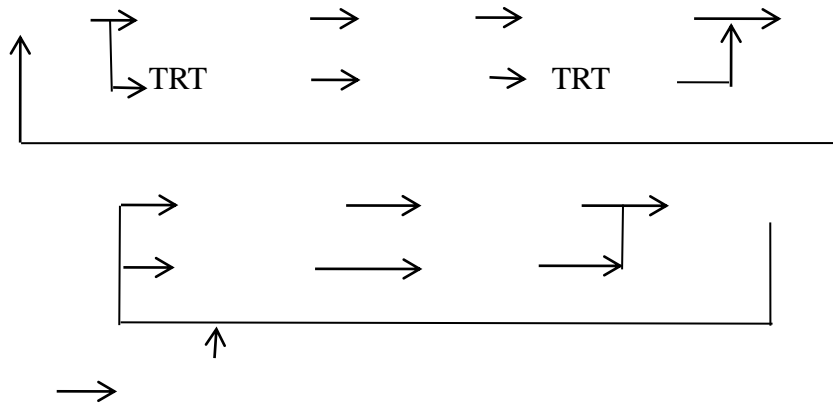

2.3-6

B.

2.3-5

					/
DA018	4#		SO ₂ NO _x	+CFB +SCR +75m	+
DA118	3#		SO ₂ NO _x	+CFB +SCR +125m	+
DA065	3#		SO ₂ NO _x	+	
DA066	4#		SO ₂ NO _x	+80m	+
DA067	5#		SO ₂ NO _x	+80m	+
DA013	3#4#			+32m	
DA016	3#			+28.5m	
DA020	4#			+38m	
DA012	3#4#			+20m	
DA091	3#4#			+18m	
DA086				+15m	
DA048	4#			+30m	

DA031	5#			+30m
DA001				+30m
DA002	YZ-6			+30m
DA087	3#4#			+15m
DA074	22#			+27m
DA085	23#			+21m
DA084	20#			+21m
DA004	15#			+20m
DA005	25#			+19m
DA006	26#			+19m
DA072	9#			+30m
DA073	18#			+24m
DA096				+25m
DA094	C			+25m
DA024	2#			+28m
DA069	3#			+28m
DA070	4#			+28m
DA025				+24m
DA095	E			+25m
DA017				+30m
DA059	4#			+35m
DA043	4#			+32m
DA088	4#			+30m
DA060	5#			+32.8m
DA046	5#			+31.7m
DA056	5#			+30m
DA029	1#			+28m
DA030	2#3#			+23m
DA015	3#			+45m
DA019	4#			+45m
DA087				+24m
DA093				+21m
DA023	1#		SO ₂ NO _x	+21m
DA010	1#2#			+23m

	DA008	1#2#			SO ₂ NO _x	+ +125m
	DA009	1#				+21m
	DA011	2#				+39m
	DA090	1#				+15m
	DA007	1#				+25m
	DA022	1#				+30m
	DA021	1#				+30m
	DA028	2#			SO ₂ NO _x	+55m
	DA027	2#3#				+24m
	DA026	2#				+26m
	DA065	3#			SO ₂ NO _x	+55m
	DA039	3#				+27m
	W1				SS	
	W2				COD BOD ₅ SS	
					2023 t	
					298551.67	
					1305116.68	
					4727.56	
					5.2	
					39294.76	

					5.304	
					/	
	N				(dB)A	

DB37/990-2019

1 /

2.4

3

2.4.1

HJ 941-2018

5

4

5km

77367

2.4-1

3

2.4-1

		m				
1		1092	SW	871		0531-76522345
2		1109	SE	1567		0531-76550550
3		1292	E	2964		0531-76622234
4		1334	SE	1096		0531-76550202
5		1432	S	601		0531-76522456
6		1477	N	931		0531-75819668

7		1509	N	2293		0531-76522446
8		1527	SE	607		0531-76550196
9		1619	S	1937		0531-76523498
10		1719	SE	1138		0531-76550154
11		1720	S	1055		0531-76523147
12		1959	NE	1022		0531-76522545
13		2042	E	875		0531-76521479
14		2056	SE	1068		0531-78550117
15		2110	E	291		0531-76656029
16		2168	S	1439		0531-76236879
17		2284	W	792		0531-76518328
18		2439	NE	2307		0531-76522992
19		2480	NW	1907		0531-76522927
20		2580	E	100		0531-76656211
21		2631	N	1068		0531-76521478
22		2652	NW	967		0531-76620422
23		2707	W	1407		0531-76511319
24		2763	NE	2084		0531-76521029
25		2810	E	367		0531-76628230
26		2852	SW	2357		0531-76518326
27		2920	S	1966		0531-76520184
28		2950	SW	691		0531-76518328
29		2950	N	894		0531-76523684
30		3063	S	502		0531-76520178
31		3072	NE	1273		0531-76521478
32		3073	NW	732		0531-76520456
33		3123	NW	937		0531-76526457
34		3199	SW	899		0531-76518241
35		3200	E	369		0531-76655193
36		3222	SW	905		0531-76518401
37		3238	S	861		0531-76520030
38		3406	S	760		0531-76520245
39		3428	W	1803		0531-76511315
40		3436	S	1789		0531-76520757
41		3445	E	1905		0531-76521477
42		3448	NW	1406		0531-76526196
43		3475	SW	1208		0531-76518225
44		3484	SE	593		0531-78615099

49		3876	NE	2751		0531-76628140
50		3948	E	2468		0531-76655037
51		3976	SE	1761		0531-78615188
52		3997	S	933		0531-76520913
53		4117	NW	903		0531-76526182
54		4144	N	805		0531-76524217
55		4160	SE	367		0531-78615261
56		4162	W	682		0531-76511283
57		4189	S	611		0531-76520040

GB36600-2018 1

3

3.1

2018 14

Q

M

E

[- Q2-M3-E1 + - Q2-M2-E3]

3.2

4.3

3.2-1

	/		CO H ₂ CH ₄		
			NH ₃		
			C ₃ H ₈		
			C ₂ H ₂		

			/		
3.3					
			CO		
		/	/	/	
		/	/	/	/
		/	/	/	/

3.3

DCS

/

1

2

()

()

4

4.1

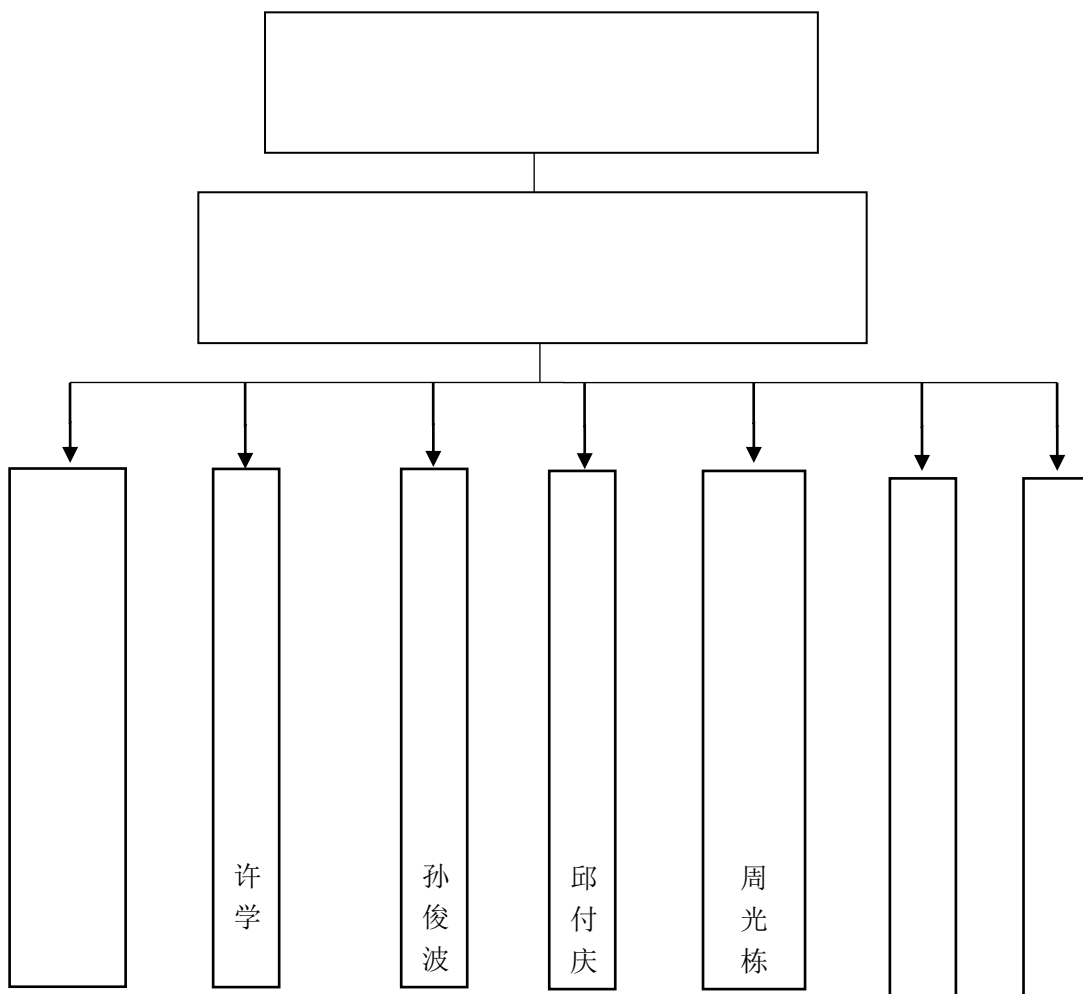

4.1-1

4.2

4.2.1

4.2.2

2

4.2.3

1

2

1

2

3

4.2.4

1

2

3

1

2

4.2.5

1

2

3

1

2

4.2.6

1

2

3

4

1

2

3

4.2.7

1

1

2

3

4

1

2

4.2.8

1

2

3

4

4.2.9

1

2

3

4

1

2

3

4

5

6

7

4.3

12

4.4

4.4-1

4.4-2

4.4-1

	24		0531-75819518	
				13561708577
				18263463698
				15515060692
				18062945667
				13837218278
				13641857785
				13506343316
				18763451749
				13561702997
				13863447397
				15866340126
				13863406584
				13806342099
				13963401829
				15863400882
				14763413462
				14706341518
				18763439192
				15166341778
				15763465978
				13863429498
				15163424203
				13863437319
				13561741267
				13963425440
				13455893444
				13563480462

				18763479623
				15163429192
				13646347826
				13863419772
				15263408528
				13963473928
				18763420899
				13963463628
				15133641539
				13561705829
				13666345744
				13563408068
				13563447156
				13963421552
				13863428388
				13906347140
				13561738442
				13969373438
				13963419172
				13863488087
				13455493893
				13563487058
				13506343316
				13963477486
				18363450128
				13561729024
				18266345458
				15106341925
				13516346644
				13561703537
				13506341874
				15263460590
				15763462615
				13468251106
				15863406951
				13863463644
				13563412349
				13963447912
				15020880403
				15166348309
				18766342202

			/	15064186667
			/	18663425138

4.4-2

			/	
1				119
2				120
3				122
4				110
5				0531-76213264
6				0531-76279088
6				0531-51707053
7				0531-51708400
8				0531-51708600
9				0531-76114187
10				0531-77996969 0531-77996966
11				0531-76210783
12				0531-76521651
10				13863449121
11				0531-75819931
12				19863482030
13				0531-76260279
	0533-2827073 0531-76556800 76556877 0532-83889090 010-63131122 12369			

4.5

- a 24
- b
- c
- d

e
f
g
h

5

5.1

1

2

3

4

5

6

7

8

9

10

11

12

13

14

5.1-1

			/	/		

1		2				
2		2				
1		2				
1		2				
1						
2						
1						
1						

5.2

5.2.1

SCR

SO₂ NO_x

5.2.2

14.5m×9m×1.35m
13m×1.5m+6m×6m×1.5m

3# 4#

27m

10^{-7} cm/s

3# 4#

0.64m³

27m³

1 48m³

1#-3#

4# 5#

4.6m³

1 1000m³

1

1000m³

4# 5#

5.2.3

1

2

3

4

5

6

7

8

9

1000m³

1 1000m³

1 48m³

1#-3#

4# 5#

4# 5#

1

10

11

DCS

12

20

5

13

CO

DCS

5.2.6

1

2

3

4

5

6

7

5.2.7

1

2

3

4

5

5.2.8

5.2.9

5.3

5.3.1

1

2

3

5.3.2

1

2

3

5.3.3

1

2

3

4

5

6

7

8

5.3-1

--	--

5.4

5.4.1

1

2

1

2

3

4

3

4

5.4.2

5.5

III

III

5.6

1

2

5.7

1

2

5.8

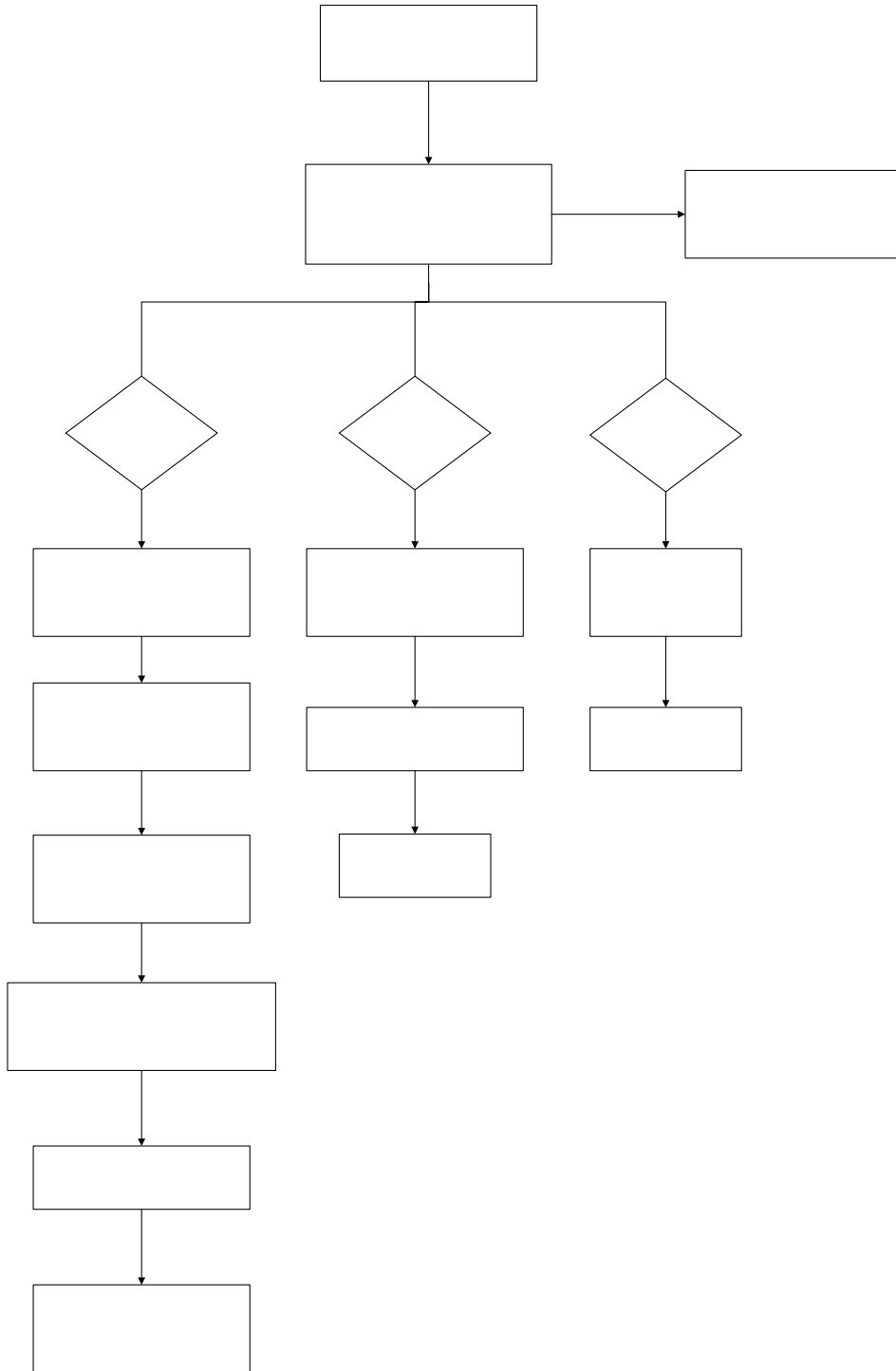

5.8-1

5.9

- 1
- 2
- 3
- 4
- 5
- 6
- 7

6

6.1

- 1
- 2
- 3
- 4

6.2

6.2.1

- 1
- 2
- 3
- 4
- 5
- 6

6.2.2

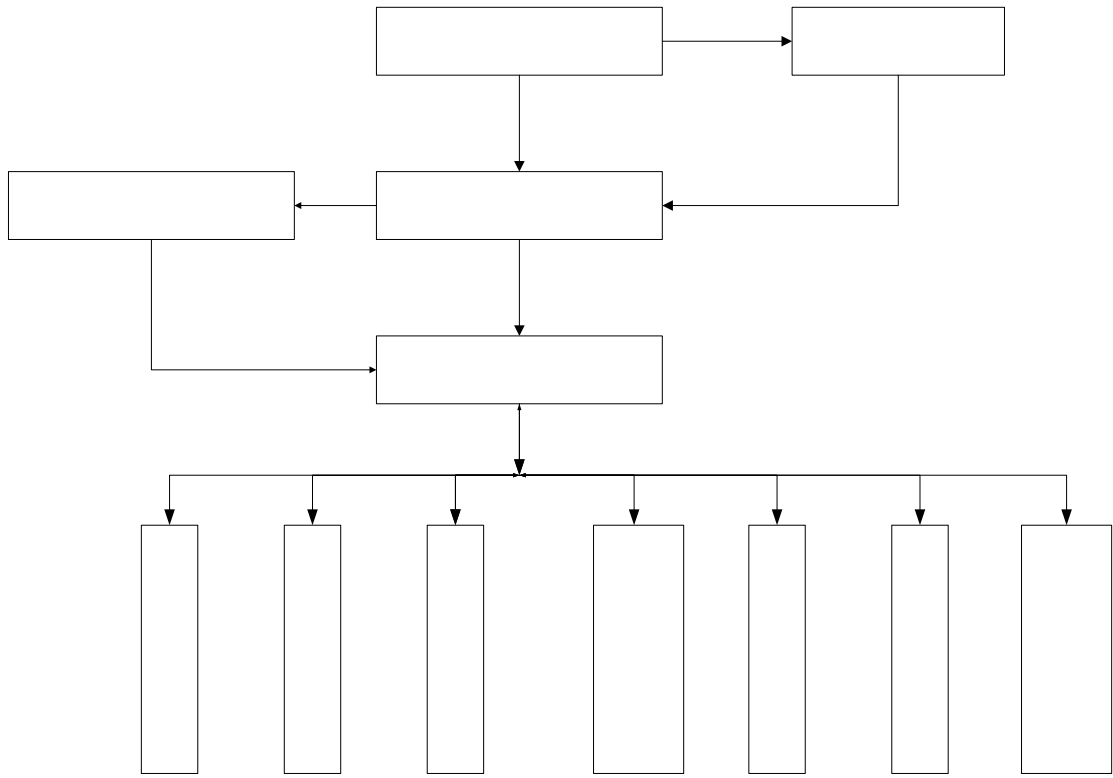

6.2-1

6.3

6.3.1

1

1

2

3

4

5

6

2

6.3.2

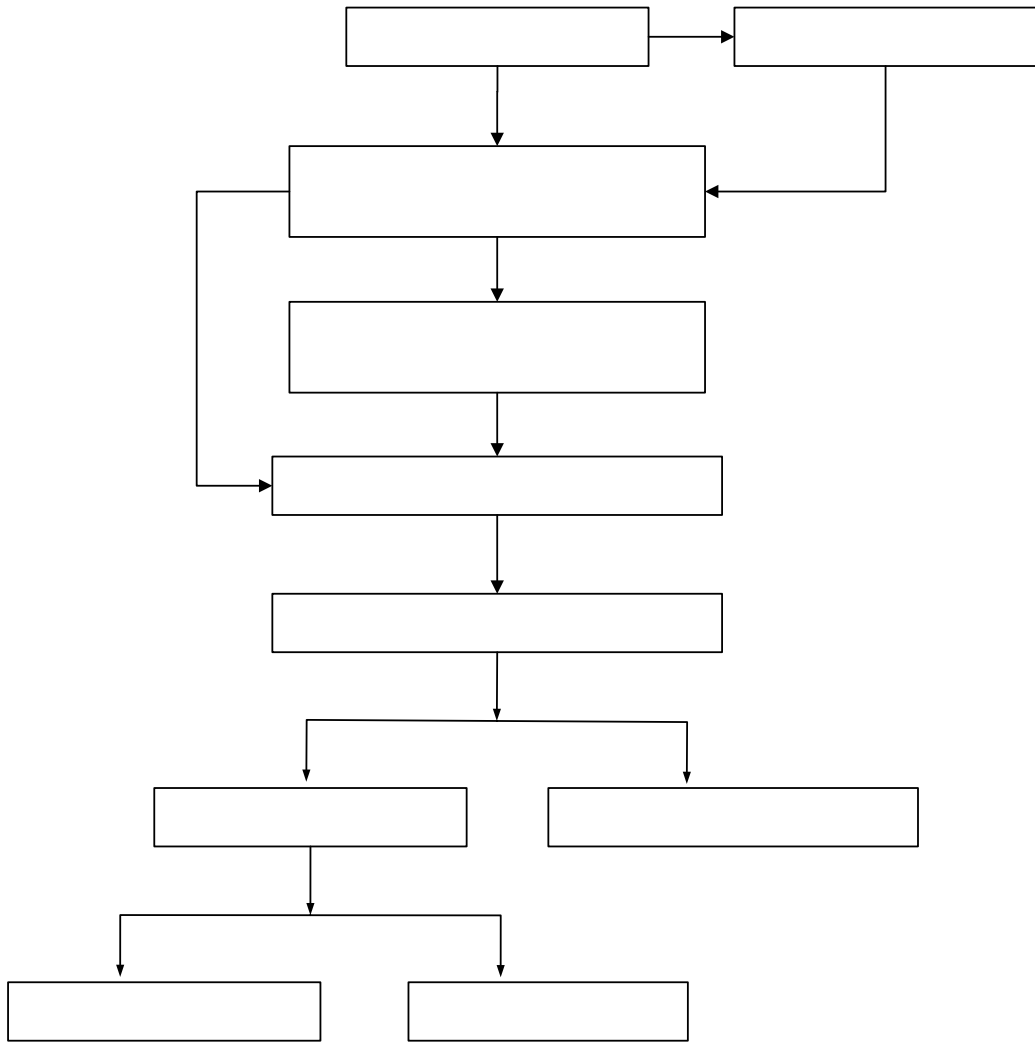

6.3-1

6.3.3

7.1

7.1.1

1

2

7.1.2

1

2

3

7.1.3

1

2

3

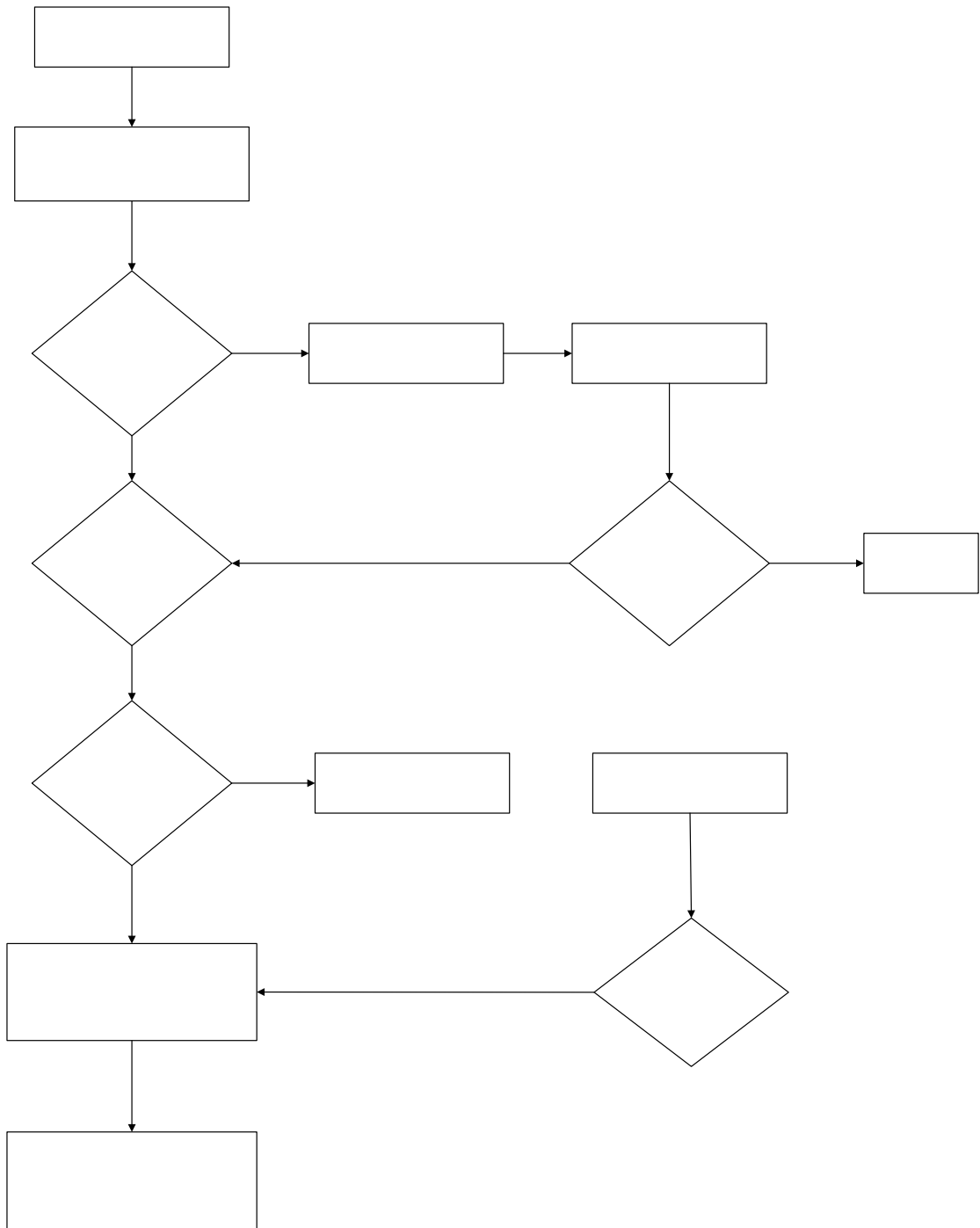

6.1-1

7.2

7.2.1

A.

1 CO
CO

2 /

3

4

5

6

7.2-1

		()
		()
	/	
	/	

B.

1

2

3

7
8
(
)
9
10

7.2.3

200

1
2
3
4
5
6

7.2.4

1
2

3

4

5

6

7

8

9

7.3

7.3.1

7.3.1.1

7.3.1.2

1
5
2

3

4

5

14--16

14--16

7.3.2

1

SO₂ NO_x

2

7.3.3

1

a.

b.

500

7.3-1

2

3

7.3.4

1

2

3

4

7.3.5

1

2

7.3-2

7.3-2

--	--	--

		()
		()
		()
		()
		()
		()

3

7.3-1

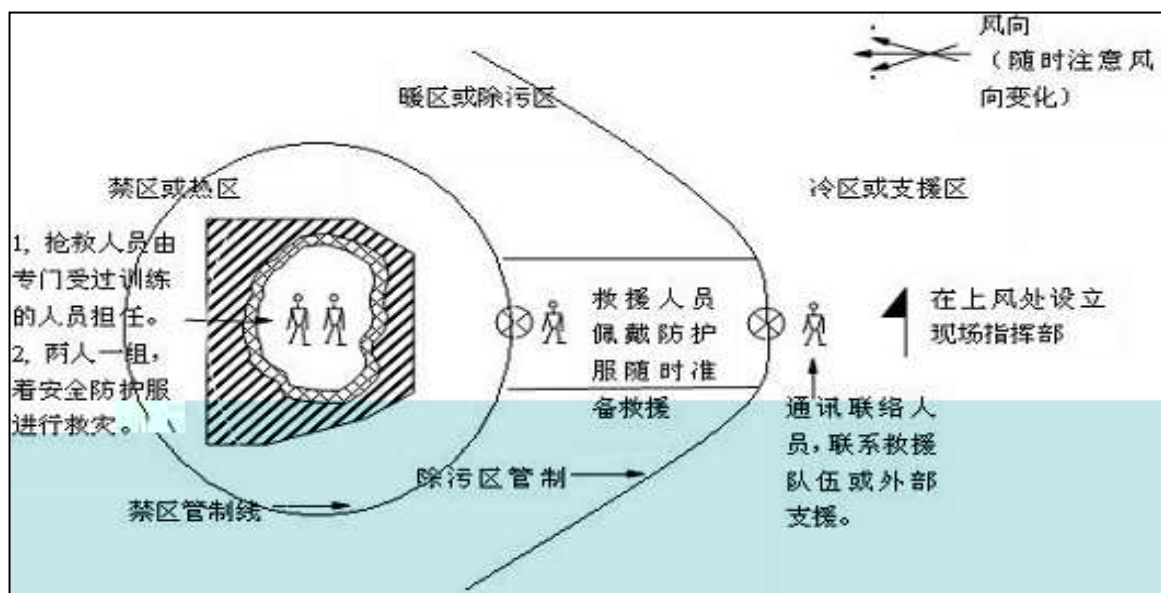

7.3-1

4

7.4

7.4.1

7.4.1.1

1

2

4-6

7.4.1.2

DB37/T3599-2019

1

2

3

1

2

a.

()

b.

)

()

(

3

a.

b.

c.

d.

e.

f.

7.4.1.6

1

2

7.4.2

1

7.4-1

	CO H ₂ CH ₄	/	/	/
	SO ₂ NO _x	/	/	/
		pH COD	/	/
	/	/	pH	pH
	/	/	pH Na ⁺ Cl ⁻	pH
	/	pH BOD ₅ a	pH a	pH a
	CO H ₂ S CH ₄ TSP	pH COD SS	/	/
	VOCs	COD SS	COD SS	
	CO VOCs	COD SS	COD SS	

2

7.4-2

	1	1
	0m 1# 100m	8

	2# 200m 3# 400m 4#	
		4 2
		1 2
		1

3

7.4.3

3

3

7.5

1

2

3

7.6

1

2

3



7.4-1

8.1

8.1.1

1

2

3

4

5

6

8.1.2

/
/

8.2

1

2

3

9

9.1

9.2

1

2

24

3

9.3

9.4

9.4.1

2022 136

9.4.2

9.4.3

110

9.4.4

9.4.5

9.4.6

1

2

3

4

5

6

7

8

9.4.7

10

10.1

1

2

10.2

1

1

2

3

4

5

6

7

2

1

2

3

4

5

6

3

1

2

3

4

5

6

10.3

1

2

3

1

2

3

4

5

10.4

10.4.1

11

11.1

1

1

2

3

2

3

4

HJ/T 298

5

6

7

8

9

10

11

11.2

11.3

1

1.1.

1.2

1.3

1.3.1

1.3.2

1

2

3

4

()

5

6

7

8

9

10

1.3.3

1.3.4

1

2

3

/

4

5

6

1.4

2

4.2

3

3.1

1 CO

2

3

4

3.2

1

--

--

--

()

--

M2/M3

1/10

--

--

CO

2

3

4

5

6

1-2

7

:

24

3.3

1 ()

2 ()

3

4

4.1

1 24

24

0531-75819518

2

4.2

1

2

3

()

4

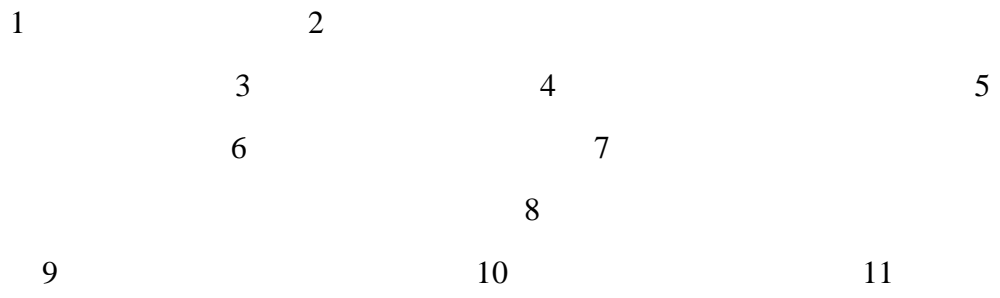

4.3



5

5.1



3

5.2

5.2.1

1

2

3

4

5

6

()

7

8

9

CO 30mg/m³(24PPm)

CO 50mg/m³(40PPm

1

CO 100mg/m³(80PPm

0.5

CO 200mg/m³(100PPm)

15-20

2

10

1

2

(

)

3

4

5

6 10m

7

8

9

10

11

CO

1

2

3

4

5

6

5.2.2

1

2

3

4

4

5

6

5.2.4

1

119

2

3

4

5

5.2.5

5.3

1

2

3

6

1

2 1000m³

2

7

1

1.1.

1.2

1.3

1.3.1

4

1.3.2

1

2

()

3

4

1.3.3

1.3.4

1

2

3

4

5

6

7

1.4

2

4.2

3

3.1

1

2

3

3.2

1

--

()

--

--

--

2

3

4

5

6

1-2

7

24

3.3

1 ()

2 ()

3

4

4.1

1 24

24

0531-75819518

2

4.2

1

2

3

()

4

1

2

3

4

5

6

7

8

9

10

11

4.3

1

2

3

4

()

5

6

7

5

5.1

1

2

3

5.2

5.2.1

1

2

3

4

5

6

7

1

2

(

)

3

4

5

5.2.2

1

2

3

4

5

5.2.3

6

1

2 1000m³

2

7

1

1.1.

1.2

1.3

1.3.1

1

				t	
				5.304	
				/	

1.3.2

1.3.3

1

2

3

IOS14001

1.3.4

1

GB18597-2023

200mm

150mm

-10 /

1 -7 /

2

a.

b.

c.

1.3.5

1.3.6

2

4.2

3

3.1

1

2

3

4

5

6

7

8

9

3.2

1

1

2

3

4

5

2

4

4.1

4.2

1

1

2

3 4 5
2
3
4
1 2
3 4 5
6 7
8
9 10 11

5

5.1

1
1
2
2
1
2
3

3

5.2

1

2

6

1

2

3

4

1

2

3

- 1.
- 2.
- 3.

4

5

1

2

6

1

2

3

4

5

1

2

891kPa

-77.7

-33.5

20

17.03

uâ

3

3 100 100

4

5

6

7

8

5

1

2

2%

3

15

6

1

2

3

4

5

6

6.

5

15

6

1

2

3

4

5

1

2

3

- 1.
- 2.
- 3.
- 4.
- 5.

4

- 1.
- 2.
- 3.
- 4.

4.

6

1

2

3

4

5

6

1

2

3

4

1

2

2.1

SO₂ NO_x

2.2

3

3.1

3.2

a

b

3.3

a

b

- 1
- 2
- 3
- 4
- 5
- 6
- 7
- 8
- 9
- 10
- 11
- 12

- 1
- 2
- 3
- 4
- 5
- 6
- 7
- 8
- 9
- 10
- 11

5km

10km